

Touwslagerstraat 13 - 2984 AW Ridderkerk  
Postbus 424 - 2980 AK Ridderkerk  
Tel. 0180 - 41 08 88  
Fax 0180 - 41 00 38  
E-mail: info@pakor.nl  
internet: http://www.pakor.nl

## TECHNISCHE INFORMATIE / TECHNICAL INFORMATION

### KERAMISCHE ZUURBESTENDIGE STENEN EN TEGELS

6.1

#### NORMAAL- STENEN

type: SF/NF

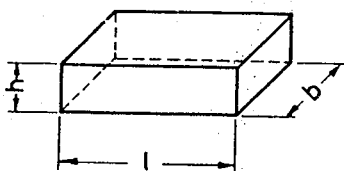

	N30	N40	N50	N64	N80	N95
l =	240	240	240	240	240	240
b =	115	115	115	115	115	115
h =	30	40	50	64	80	95
kg/st	1,78	2,37	2,97	3,80	4,75	5,64

#### SPLIJT- TEGELS

S=splijt  
D=dunbed

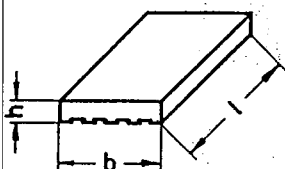

	S13	S15	S20	S25	S30	S40
	D13	D15	D20	D25	D30	D40
l =	240	240	240	240	240	240
b =	115	115	115	115	115	115
h =	13	15	20	25	30	40
kg/st	0,78	0,80	1,15	1,40	1,80	2,40

#### KOP-AFDEK SPLIJTTEGELS

S=splijt  
D=dunbed

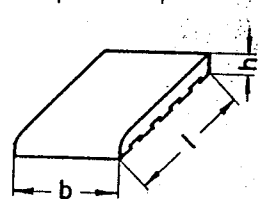
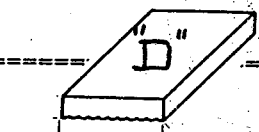

	SB 15	SB 20	SB 25
	DB 15	DB 20	DB 25
l =	240	240	240
b =	115	115	115
h =	15	20	25
kg/st	0,80	1,15	1,40

#### LANGS-AFDEK SPLIJTTEGELS

S=splijt  
D=dunbed

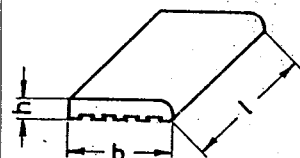

	SL 15	SL 20	SL 25
	DL 15	DL 20	DL 25
l =	240	240	240
b =	115	115	115
h =	15	20	25
kg/st	0,80	1,15	1,40

#### HOEK-AFDEK SPLIJTTEGELS

S=splijt  
D=dunbed

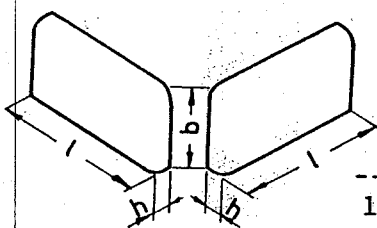

	HOEK RECHTS			HOEK LINKS		
	SER15	SER20	SER25	SEL15	SEL20	SEL25
	DER15	DER20	DER25	DEL15	DEL20	DEL25
l =	240	240	240	240	240	240
b =	115	115	115	115	115	115
h =	15	20	25	15	20	25
kg/st	0,80	1,15	1,40	0,80	1,15	1,40

#### DUBBELLANGS- AFDEK- SPLIJTTEGEL

type:  
splijttegel

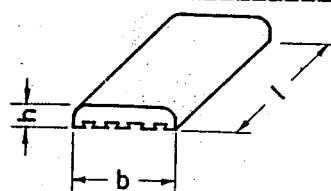

	SD
l =	240
b =	115
h =	25
kg/st	1,4

Touwslagerstraat 13 - 2984 AW Ridderkerk  
Postbus 424 - 2980 AK Ridderkerk  
Tel. 0180 - 41 08 88  
Fax 0180 - 41 00 38  
E-mail: info@pakor.nl  
Internet: http://www.pakor.nl

**TECHNISCHE INFORMATIE / TECHNICAL INFORMATION**

**KERAMISCHE ZUURBEST. PLINTEN, RAND- EN GOOTBODEMSTENEN 6.2**

**PLINTEN**

type:  
splijttegel

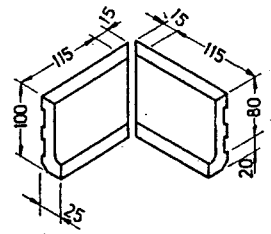
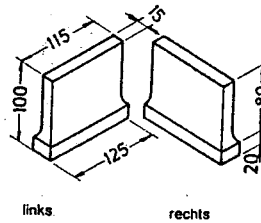
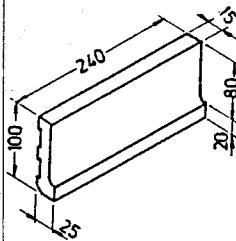

PLINT  
K  
1, 2

UITW.HOEK LINKS...KAL  
UITW.HOEK RECHTS...KAR  
0, 7

INW.HOEK  
VERSTEK...KI  
1, 3

kg/stuk

**RANDSTENEN**

type:  
SF/NF

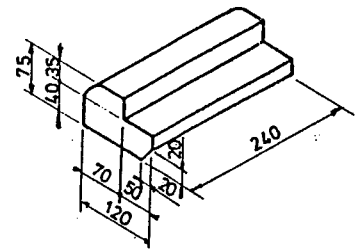
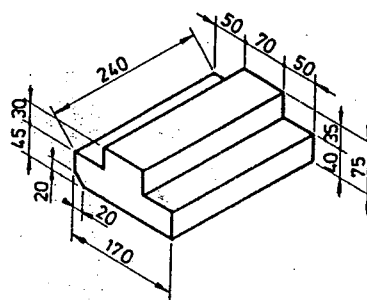
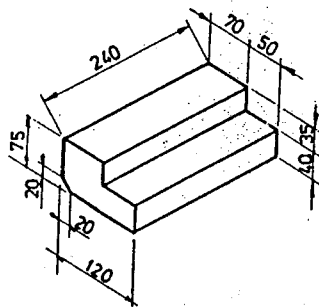

FELSRANDSTEEN  
F  
3, 7

DUBBELFELSRANDSTEEN  
FF  
5, 1

FELSRAND-RONDSTEEN  
FR  
3, 4

kg/stuk

**GOOTBODEM-STENEN**

type:  
SF/NF

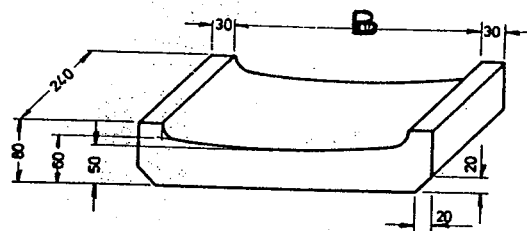

B kg/st

R 20	200	6,8
R 30	300	10,95
R 40	400	13,90

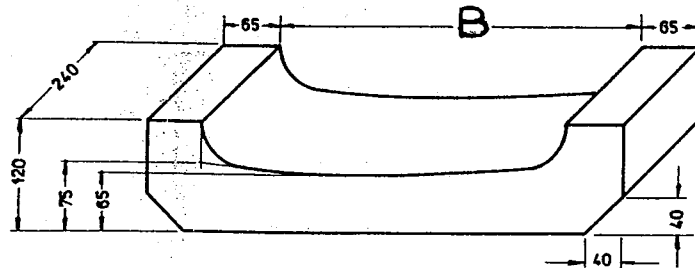

B kg/st

R 25	B 250	17,35
R 28	B 280	19,72
R 40	B 400	21,89
R 50	B 500	25,50



Touwslagerstraat 13 - 2984 AW Ridderkerk  
Postbus 424 - 2980 AK Ridderkerk  
Tel. 0180 - 41 08 88  
Fax 0180 - 41 00 38  
E-mail: info@pakor.nl  
Internet: http://www.pakor.nl

**TECHNISCHE INFORMATIE / TECHNICAL INFORMATION**

**KERAMISCHE VERANKERINGSSTEEN/SLEEVES/MANTELSTENEN/WIGGEN 6.3**

**VERANKERINGS-  
STEEN**

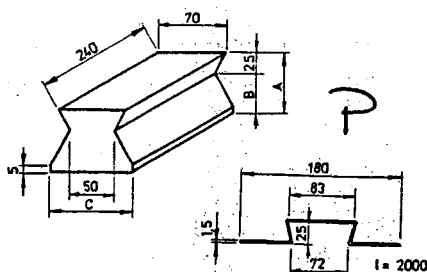

	A	B	C	kg/st
V 15	48	23	68	1,48
V 25	58	33	78	1,88
V 35	68	43	80	2,22
V 40	73	48	83	2,42
V 65	105	80	120	4,31
P				5,0

Type:  
SF A

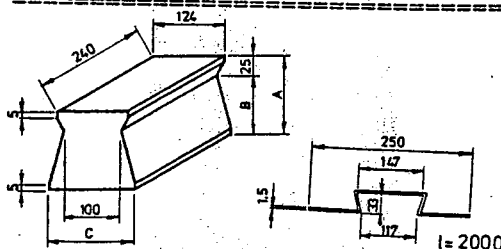

VS 50	83	58	127,5	4,85
VS 65	98	73	135,5	5,88
VS 80	113	88	144,5	7,00
VS 95	128	103	151,5	8,10
VS 115	148	123	162,5	9,75
PS				7,9

**SLEEVES**

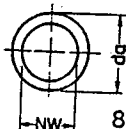
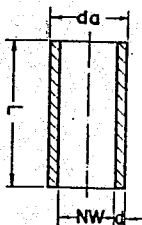

NW	88/20	89/30	90/40	91/50	92/60	93/70	94/80	95/90	96/100	97/120
----	-------	-------	-------	-------	-------	-------	-------	-------	--------	--------

NW	20	30	40	50	60	70	80	90	100	120
da	50	70	80	100	120	130	140	150	160	180
d	15	20	20	25	30	30	30	30	30	30
L	200	200	300	300	300	300	300	300	300	300
kg/s	0,70	1,33	2,40	3,75	5,39	6,00	6,60	7,20	7,79	8,99

Type: SF A

**MANTELSTENEN**

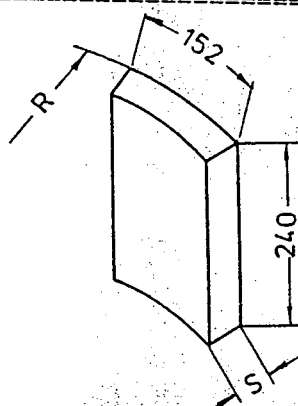

	M8	M12	M16	M20	M30
R	400	600	800	1000	1500

gewicht per stuk bij s=

30	2,23	2,26	2,27	2,28	2,30
40	2,93	2,99	3,01	3,04	3,06
50	3,61	3,70	3,74	3,77	3,81
65	4,60	4,74	4,81	4,86	4,91
80	5,55	5,76	5,86	5,93	6,02
100	6,75	7,07	7,23	7,33	7,48

Type: SF A

**KOPWIGSTEEN**

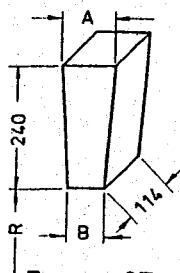

Type: SF A

**STREKWIGSTEEN**

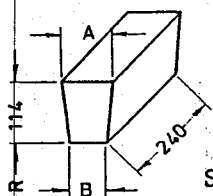

	G4	G6	G10	G16	G24	H4	H6	H10	H16	H24
A	78	79	81	84	88	78	79	81	84	88
B	74	73	71	68	64	74	73	71	68	64
R	4740	3120	1824	1095	690	2252	1482	867	520	328
St/ring	377	252	151	95	63	179	119	72	45	30
kg/st	4,41					4,41				

Touwslagerstraat 13 - 2984 AW Ridderkerk  
Postbus 424 - 2980 AK Ridderkerk  
Tel. 0180 - 41 08 88  
Fax 0180 - 41 00 38  
E-mail: info@pakor.nl  
Internet: http://www.pakor.nl

## TECHNISCHE INFORMATIE / TECHNICAL INFORMATION

### KERAMISCHE ZUURBEST. KONUSSTENEN/VORMSTENEN/BODEMPLAAT 6.4

#### KONUSSTENEN

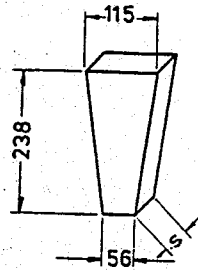

Type: SF A

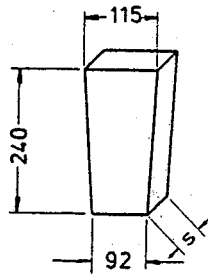

	K23/3	K23/4	K23/5	K23/6	K23/8	K23/10
s	30	40	50	64	80	100
kg/st	1,60	2,11	2,63	3,37	4,21	5,27

#### K59/3 K59/4 K59/5 K59/6 K59/8

s	30	40	50	64	80
kg/st	1,29	1,73	2,16	2,76	3,45

#### RADIAALSTENEN

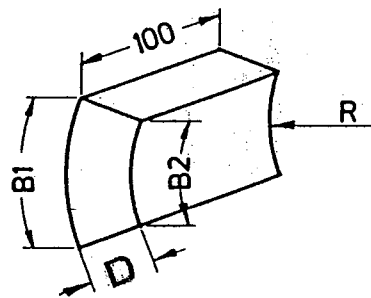

Type: SF A

	D	R	B1	B2	kg/st
H 10-30	30	65	100	68	0,53
H 15-30	30	100	100	76	0,55
H 20-30	30	150	100	83	0,58
H 25-30	30	200	125	109	0,74
H 35-30	30	300	125	114	0,76
H 10-40	40	55	100	58	0,67
H 15-40	40	95	100	67	0,71
H 20-40	40	135	100	77	0,75
H 25-40	40	185	125	103	0,96
H 35-40	40	285	125	109	1,01
H 10-50	50	45	100	47	0,78
H 15-50	50	80	100	62	0,86
H 20-50	50	130	100	72	0,91
H 25-50	50	180	125	98	1,18
H 35-50	50	280	125	108	1,23
H 10-65	65	30	100	32	0,90
H 15-65	65	65	100	52	1,05
H 20-65	65	115	100	64	1,13
H 25-65	65	165	125	89	1,47
H 35-65	65	265	125	102	1,56

#### BODEMPLAAT

type:  
SF G

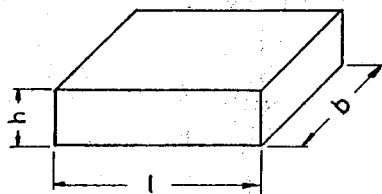

	U1	U2	U3	U4	U5	U6
l =	240	240	365	365	300	400
b =	240	240	240	240	300	200
h =	65	60	65	80	95	95
kg/st	8,05	9,91	12,24	15,07	18,38	16,34



Touwslagerstraat 13 - 2984 AW Ridderkerk  
Postbus 424 - 2980 AK Ridderkerk  
Tel. 0180 - 41 08 88  
Fax 0180 - 41 00 38  
E-mail: info@pakor.nl  
Internet: http://www.pakor.nl

**TECHNISCHE INFORMATIE / TECHNICAL INFORMATION**

**KERAMISCHE ZUURBESTENDIGE BODEMSTENEN**

6.5

Type	R	b	Stuks per ring	Gewicht in kg/stuk voor s =							
				30	40	50	65	80	100		
	A1	250	-	6	2,04	2,72	3,40	4,44	5,45	6,81	
	A2	495	76	20	1,74	2,32	2,90	3,77	4,64	5,80	
	A3	740	101	30	1,93	2,57	3,22	4,18	5,15	6,44	
	A4	985	114	40	2,03	2,71	3,39	4,40	5,42	6,77	
	A5	1230	121	50	2,09	2,78	3,48	4,52	5,56	6,95	
	A6	1475	126	59	2,12	2,83	3,55	4,60	5,66	7,07	
	A7	1720	130	69	2,15	2,87	3,59	4,66	5,74	7,17	
	B1	0	300	-	1	4,49	6,00	7,49	9,74	11,98	14,98
	B2	395	57	16	1,59	2,13	2,66	3,46	4,25	5,32	
	B3	640	93	26	1,87	2,49	3,12	4,05	4,99	6,23	
	B4	885	109	36	1,99	2,66	3,32	4,32	5,14	6,64	
	B5	1130	119	46	2,07	2,76	3,45	4,48	5,52	6,89	
	B6	1375	125	55	2,11	2,87	3,52	4,58	5,64	7,09	
	B7	1620	129	65	2,17	2,86	3,57	4,65	5,72	7,15	

Type: SF A

 Touwslagerstraat 13 - 2984 AW Ridderkerk  
 Postbus 424 - 2980 AK Ridderkerk  
 Tel. 0180 - 41 08 88  
 Fax 0180 - 41 00 38  
 E-mail: info@pakor.nl  
 Internet: http://www.pakor.nl

**TECHNISCHE INFORMATIE / TECHNICAL INFORMATION**
**FYSISCHE EIGENSCHAPPEN ZUURBESTENDIGE STEENMATERIALEN 6.6**

Type	PRE klassi- fikatie	s.g g/cm <sup>3</sup>	water- opname WA, gew.%	open porien Ps vol.%	koude drukvast- heid KDF N/mm <sup>2</sup>	TWB 2) aantal afschrik- kingen	zuur- oplos- baar, SL gew.%
SF A	1A	2,12	≤ 6	≤ 13	≥ 60	≥ 6	≤ 1,2
SF C	1B	2,15	≤ 7	≤ 16	≥ 50	≥ 12	≤ 1,0
SF D	1A	2,30	≤ 2	≤ 5	≥ 100	≥ 5	≤ 1,0
SF G	1A	2,10	≤ 7	≤ 15	≥ 50	≥ 8	≤ 1,2
SF H	1A	2,10	≤ 7	≤ 15	≥ 50	≥ 10	≤ 1,8
SF K	1A	2,10	≤ 7	≤ 15	≥ 60	≥ 8	≤ 1,2
SF M	1B	2,05	≤ 8	≤ 17	≥ 40	≥ 10	≤ 1,8
SF NF	1A	2,15	≤ 5	≤ 11	≥ 80	≥ 5	≤ 1,2
Splijttegels	1A	2,20	≤ 4	≤ 9	≥ 80	≥ 10	≤ 1,2

**Karakterisering:**

SF A	voor normale toepassingen in de chemiebouw
SF C	kwaliteit die bestand is tegen zware thermische wissellasten
SF D	uiterst dichte kwaliteit
SF G	als SF A, maar met een betere TWD
SF H	kwaliteit met beperkte zuurbestandheid
SF K	schoorsteen kwaliteit
SF M	vuurvaste kwaliteit met goede TWB en goede chemische bestandheid
SF NF	normaalsteen-kwaliteit

**Gegevens** De vermelde gegevens zijn gemiddelde waarden, verkregen uit machinaal gevormde normaalstenen en soortgelijke formaten; ze zijn bepaald volgens de geldende DIN-Normen

**Maattoleranties** Geextrudeerde produkten: +/- 2%, bij maten ≤ 100 mm +/- 2 mm  
Droog geperste stenen: +/- 1%, bij maten ≤ 150 mm +/- 1,5 mm

**Doorbuiging** Bij geextrudeerde produkten tot 1,5 % en bij geperste stenen tot 1 % van de grootste maat.

**Warmtegeleiding** Lambda in W/m K, richtwaarden:  
 bij 200 gr.C      500 gr.C      1000 gr.C      1200 gr.C  
 1,00                      1,15                      1,45                      1,60

**PRE-klassi-  
fikatie** volgens 40.PRE-aanbeveling  
 1 = SL ≤ 2 gew.%  
 A = open porien ≤ 15 vol.%  
 B = open porien ≥ 15 vol.%

**Loogbestandheid** voor splijttegels: ≤ 4%

1) afwijkingen +/- 0,05 g/cm<sup>3</sup>

2) TWB volgens DIN 51068 (water) - 450 gr.C testtemperatuur.



Touwslagerstraat 13 - 2984 AW Ridderkerk  
Postbus 424 - 2980 AK Ridderkerk  
Tel. 0180 - 41 08 88  
Fax 0180 - 41 00 38  
E-mail: info@pakor.nl  
Internet: http://www.pakor.nl

**TECHNISCHE INFORMATIE / TECHNICAL INFORMATION**

**KONUSSTENEN IN K-STENEN SYSTEEM**

6.8

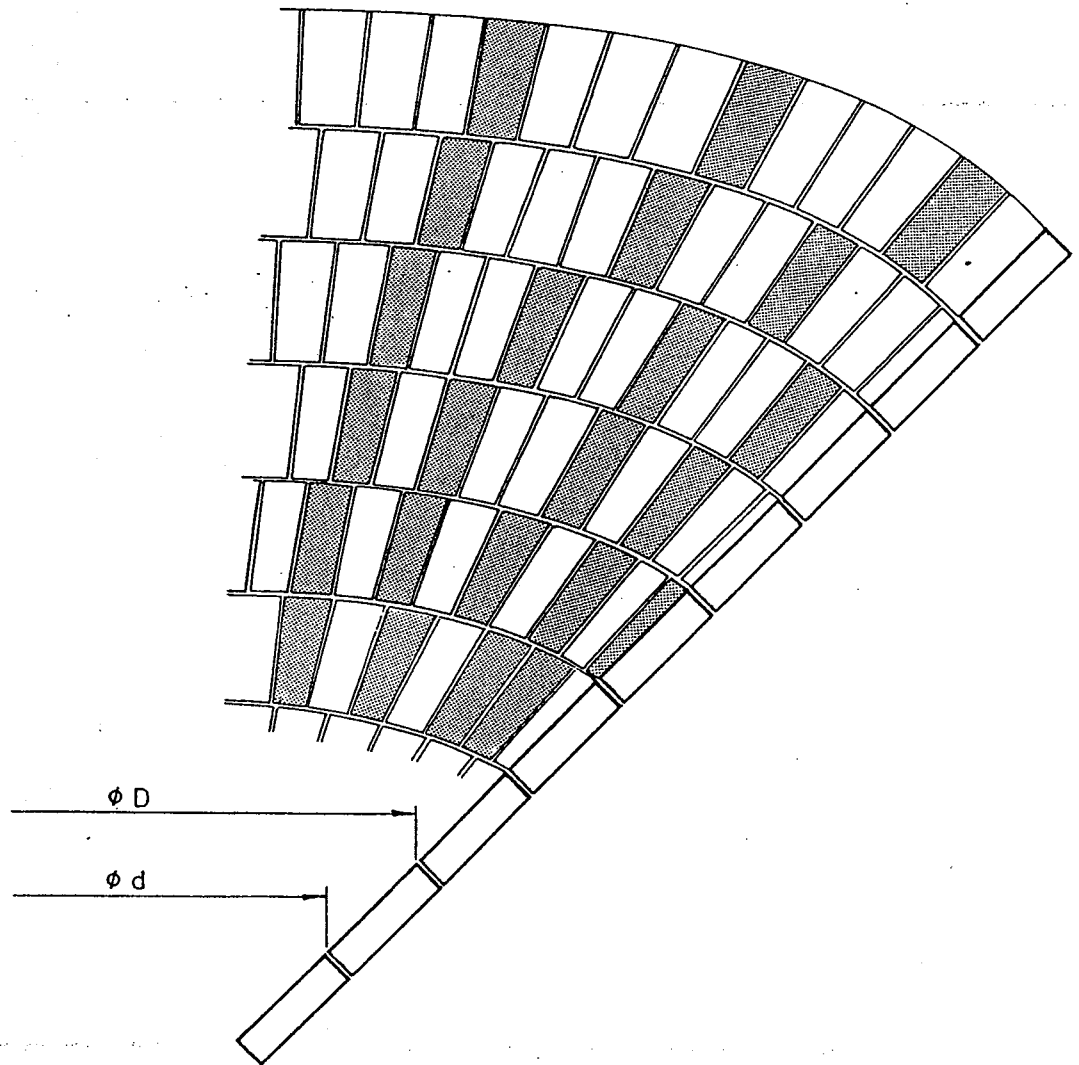

Voorbeeld berekening:

Toepassing K59

$$\frac{(D-d) \cdot \pi}{59} = \dots \text{ stuks K59}$$

K = Konussteen  
N = Normaalsteen

$$\frac{D \cdot \pi}{120} - \frac{(D-d) \cdot \pi}{59} = \dots \text{ stuks N}$$

Toepassing K23

$$\frac{(D-d) \cdot \pi}{23} = \dots \text{ stuks K23}$$

$$\frac{D \cdot \pi}{120} - \frac{(D-d) \cdot \pi}{23} = \dots \text{ stuks N}$$